



## SEIBU ELECTRIC & MACHINERY CO., LTD.

TEL+81-92-941-1507 FAX+81-92-941-1517

Head Office & Factory	〒811-3193 3-3-1 Eki-higashi, Koga, Fukuoka	TEL +81-92-943-7071 FAX +81-92-941-1511
Tokyo Branch	〒136-0071 Tachibana Kameido Bldg 3F, 2-26-11 Kameido, Koto-ku, Tokyo	TEL +81-3-5628-0015 FAX +81-3-5628-0023
Osaka Branch	〒530-0001 Mainichi Shimbun Bldg 5F, 3-4-5 Umeda, Kita-ku, Osaka	TEL +81-6-4796-6711 FAX +81-6-4796-6707
Nagoya Sales Office	〒468-0015 2-3101 Hara, Tenpaku-ku, Nagoya	TEL +81-52-800-5051 FAX +81-52-800-5030
Kyushu Sales Office	〒811-3193 3-3-1 Eki-higashi, Koga, Fukuoka	TEL +81-92-941-1530 FAX +81-92-941-1522
Hiroshima Sales Office	〒730-0013 1-17 Hatchobori, Naka-ku, Hiroshima	TEL +81-82-502-1651 FAX +81-82-502-1653
Sapporo Local Office	〒060-0033 8-352 Kita Sanjo Higashi, Chuo-ku, Sapporo	TEL +81-11-221-0521 FAX +81-11-221-3392
Sendai Local Office	〒980-0802 Dplanner Futukamachi Bldg #201, 17-22 Futukamachi, Aoba-ku, Sendai	TEL +81-22-797-6695 FAX +81-22-797-6696
Tokyo Service Center	〒272-0014 1-13-2 Tajiri, Ichikawa, Chiba	TEL +81-47-378-7261 FAX +81-47-378-7266
Osaka Service Center	〒567-0803 1-17 Nakasoujijicho, Ibaraki, Osaka	TEL +81-726-30-5850 FAX +81-726-30-5852

<http://www.seibudenki.co.jp>

Seibu Electric is  
accredited under ISO9001.



Be sure to read the "Instruction Manuals" and "Safety Precaution Manual" before use to ensure proper and safe use.

- Reference values in this catalog are based on in-house testing only.
- Products in this catalog are controlled products and/or technologies as covered in the Foreign Exchange and Foreign Trade Law of Japan. An export license from the Japanese government is required for export of these products or software.

Agency

Seibu

Next Generation of Intelligent Valve Actuators

# Semflex

**A** Series  
**VM** Series  
**VP** Series

SEIBU ELECTRIC & MACHINERY CO., LTD.

All specifications subject to change without notice.

©Printed in Japan. October 2013 07-5 OB

# Controlling the World's Valves

## — Highly reliable, Intelligent Valve Actuator —

Sure and stable performance is required for valve actuators that are widely used in facilities essential to our daily lives, including those for gas, oil, water, and sewage.

The new Semflex® A, VM, and VP Series of Valve Actuators reflect the cutting-edge technology and expertise that have been accumulated by Seibu Electric over the years since the company began the manufacturing and sales of valve actuators in 1954.

### Compact Multi-turn type

# A

Series



Power weight ratio **World No.1**

weight **50% down**  
(compared to our conventional type.)

### Multi-turn type

# VM

Series



### Part-turn type

# VP

Series



## Installation

### Simple and Environment-resistant Construction

Semflex® valve actuators feature compact, lightweight, and simple construction with electronic sensors and can be installed in narrow spaces. Seibu strived to offer the highest level of environment resistance, including IP68-rated waterproofing and double sealing for the terminal section, as part of the standard specifications. (Explosion-proof is also available.)

#### Compliance Standards

●JIS ●CE Marking ●UL Standards

## Operation

### Excellent User Interface for Simple Setting and Adjustments

Just turn on the power and get ready for operation - an attractive feature of the Semflex® all-in-one construction with an integrated control unit. The rich array of control functions necessary for fluid control can be easily set and adjusted on the operation panel. Remote operation is available with the addition of an optional feature. For example, operation and monitoring of 125 actuators with one PC (master) in the PROFIBUS communications network is possible.

Remote operation through a cloud server or Bluetooth communications through a mobile terminal are also possible.

#### Standard Features

- Electric opening and closing of valve
- Limits and torque setting by push button operation (No need to open the cover)
- Switch between manual and electric operation (automatically reset to electric)\*
- LCD indicator

\* : The Semflex A supports only manual resetting.

## Maintenance

### Fewer Inspection Items for Reduced Maintenance Time without Sacrificing Reliability

Carefully designed for simplified inspections and easier disassembly, Semflex® reduces the time and costs spent on maintenance. The new self-diagnosis function (option) enables you to forecast when the next inspection will be needed. Because valve actuators are widely used in important facilities throughout our infrastructure, Semflex® is the best choice with its high reliability born out of Seibu's proven technological expertise and production system, the best in Japan.

# Semflex®

## Compact Multi-turn type

# A

Series

Power  
weight  
ratio **World  
No.1**



Standard  
Variable-speed

## IP68-rated Construction and Plug-in Connector

## Multi-turn type actuators to open and close valves by the linear method

### Applications

- Plants ●Maritime ●Small spaces ●Small-diameter pipes ●Plants with communications networks
- Valves that require high stopping precision ●Flow control valves ●Substituting pneumatic valve drives

### Features

#### Compact and Lightweight

*Small*

#### The Size of A3 Paper

Downsizing the actuator simplifies pipe design and helps overall downsizing in plants.

#### Silent

*Silent*

#### Operation at 50 dB

Noise during operation has been reduced by not using A/B gears.

#### Standard Variable-speed Operation

*Speed Control*

#### Sleeve speed: 1 to 100 min<sup>-1</sup>

Variable-speed operation is possible with servomotor speed control. A SURFDRIVE (minute motor shaft vibration) function is used to increase the efficiency of the internal gears and reduce the size of the motor.

### Controller Specifications

Function	Specification
Main power supply	Three-phase 200/400 VAC Single-phase 200 VAC
Control CPU	16-bit CPU with A/D D/A converters 25 MHz
Position detection	Resolver sensor 100,000 pulses per output shaft rotation
Torque detection	Accuracy ±10%
LCD	Open %, m, °, alarm display icon, 3-character data
Basic operation	Open, stop and close push button operation Switching between local/remote
Opening/closing speed adjustment	Servomotor (standard)
Position adjustment	0%, 100% and five freely selectable points in between
Torque adjustment	Freely adjustable between 20% and 100% of max. torque
Option	Proportional control (4 to 20 mA) PROFIBUS-DP communications

### Mechanical Specifications & Dimensions

Specification	Model	Semflex® A Series	
		A-50	A-100
Max. output torque (Nm)		50	100
Max. thrust (kN)		25	54
Fitting flange size (ISO)		F07	F10
Max. shaft dia. (mm)	Rod	28	38
	Screw	30	40
Output speed (min <sup>-1</sup> )		1 to 100	
Ambient temperature (°C)		-20 to 60	
Protection structure		IP68 (standard)	
Weight (kg)		15	16
Outer dimensions (mm)	φA	90	125
	φB <sup>18</sup>	55	70
	φC	70	102
	D	4	4
	E	M8	M10
	F	12	16
	G	47	50
	H	181	185
	I	265	270
	J	446	455
	K	12	14
	L	230	216
	M	3	3
	N	102	97
	O	25	16
	P	100	105
Q	110	110	
R	104	104	

Note : For improvement of performance, mechanical specifications and/or outer dimensions are subject to change without notice.

### Dimensions (mm)

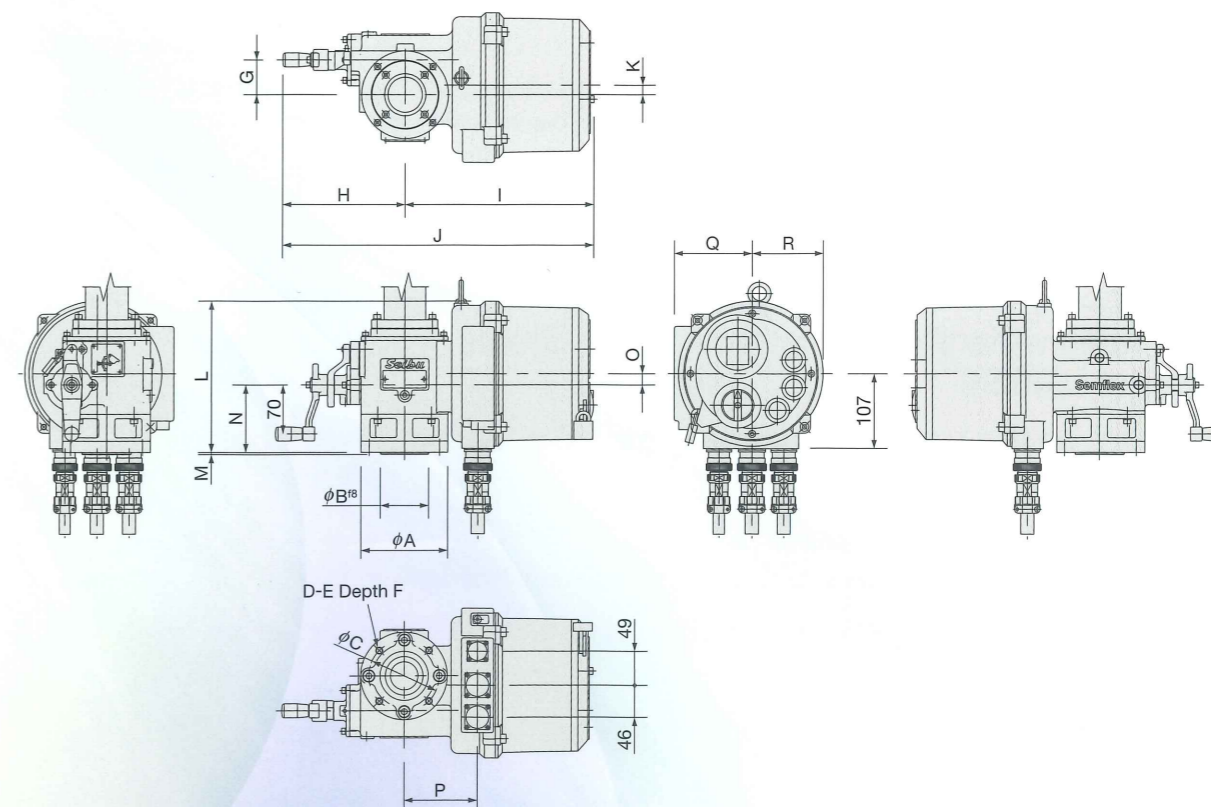

# Semflex®

## Multi-turn type

# VM Series



## Multi-turn type actuators to open and close valves by the linear method

### Applications

- Plants ●Building air conditioning ●District cooling and heating ●Production systems
- Industrial water inflow line ●Inflow around filter beds in water purification plants
- Hot and cold water flow-rate control in district cooling and heating systems

### Features

Dramatically decreased failure caused by water immersion with IP68-rated waterproof construction and double sealing of the terminal section

Just turn on the power to get ready for valve opening and closing operation.

A variety of control is available.

(Water-hammer prevention, valve purging, and torque retry function, etc.)

Opening and closing speed is adjustable with installation of an inverter (option).

Easy addition of the 2-wire communications network (PROFIBUS-DP) for remote control (option)

Flameproof construction Exd II BT4 (option)

Simple construction leading to significantly reduced inspection time and cost

### Controller Specifications

Function	Specification
Main power supply	Three-phase 200/400 VAC
Control CPU	16-bit CPU with A/D D/A converters 16 MHz
Position detection	Electronic absolute encoder 72 pulses per output shaft rotation
Torque detection	Accuracy $\pm 10\%$
LCD	Open %, alarm display icon, indicator, 3-character data
Basic operation	Open, stop and close push button operation Switching between local/remote
Opening/closing speed adjustment	Inverter (option)
Position adjustment	0%, 100% and four freely selectable points in between
Torque adjustment	Freely adjustable between 30% and 100% of max. torque
Option	Proportional control (4 to 20 mA) Inverter (variable speed) PROFIBUS-DP communications

### Mechanical Specifications & Dimensions

Specification	Model	Semflex® VM Series			
		VM-01	VM-04	VM-07	VM-1
Max. output torque (Nm)		150	550	850	1800
Max. thrust (kN)		70	130	160	270
Fitting flange size (ISO)		F10	F14	F16	F25
Max. shaft dia. (mm)	Rod	34	50	60	80
	Screw	40	58	72	95
Output speed (min <sup>-1</sup> )		Approx. 10 to 90 (choosing from 8 pairing gears)			
Ambient temperature (°C)		-20 to 60			
Protection structure		IP68, Exd II BT4 explosion-proof (option)			
Weight (kg)		40	65	100	160
	$\phi A$	125	175	210	300
$\phi B^{\#}$		70	100	130	200
	$\phi C$	102	140	165	254
D		4	4	4	8
	E	M10	M16	M20	M16
F		30	38	45	43
G		25	22	146	173
H		283	298	445	479
I		285	310	325	375
J		568	608	770	854
K		44	48	88	115
L		287.5	340.5	342	365
M		320	370	417.5	468
N		3	4	3	5
O		216	260	276	305
P		147	170	200	225
Q		135	132	110	113
R		37	90	90	100
S		15	18	40	40
T		216	260	276	305
$\phi U$		300	450	314	400

Note : For improvement of performance, mechanical specifications and/or outer dimensions are subject to change without notice.

### Dimensions (mm)

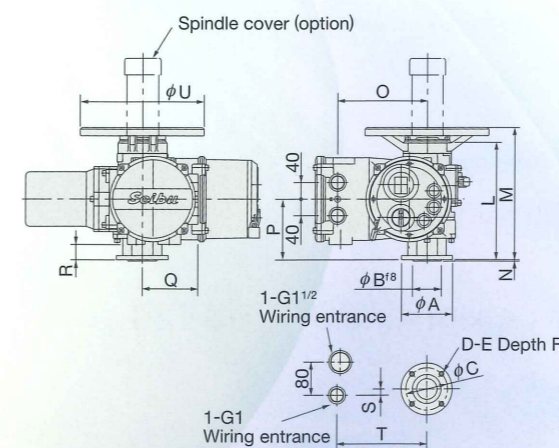
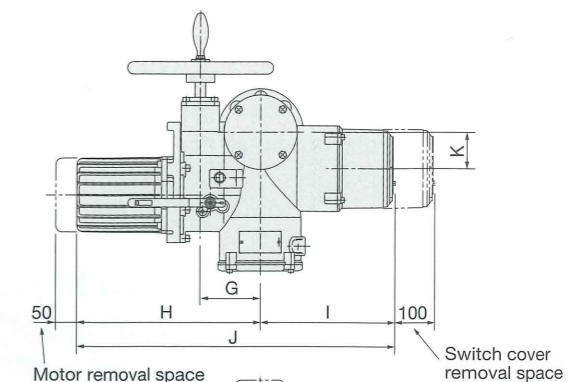
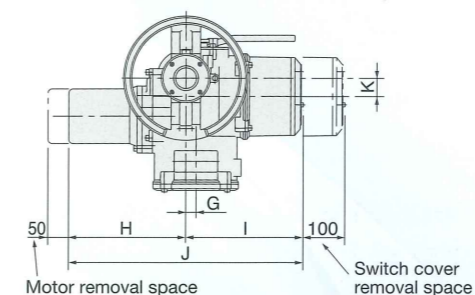

Model : VM-01, VM-04

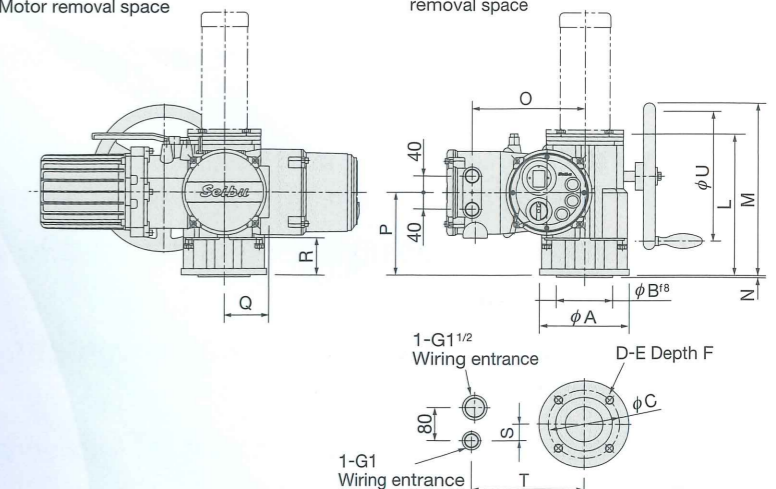

Model : VM-07, VM-1

# Semflex®

## Part-turn type

# VP

Series



Part-turn type actuators to open and close valves by turning them 90 degrees

### Applications

- Building air conditioning
- District cooling and heating
- Production systems
- Plants
- Industrial water inflow line
- Dampers
- Hot and cold water flow-rate control in district cooling and heating systems

### Features

Dramatically decreased failure caused by water immersion with IP68-rated waterproof construction and double sealing of the terminal section

Just turn on the power to get ready for valve opening and closing operation.

A variety of control is available.

(Water-hammer prevention, valve purging, and torque retry function, etc.)

Opening and closing speed is adjustable with installation of an inverter (option).

Easy addition of the 2-wire communications network (PROFIBUS-DP) for remote control (option)

Flameproof construction Exd II BT4 (option)

Simple construction leading to significantly reduced inspection time and cost

### Controller Specifications

Function	Specification
Main power supply	Three-phase 200/400 VAC
Control CPU	16-bit CPU with A/D D/A converters 16 MHz
Position detection	Non-contact potentiometer 500 pulses per 90° output shaft rotation
Torque detection	Accuracy ±10%
LCD	Open %, alarm display icon, indicator, 3-character data
Basic operation	Open, stop and close push button operation Switching between local/remote
Opening/closing speed adjustment	Inverter (option)
Position adjustment	0%, 100% and four freely selectable points in between
Torque adjustment	Freely adjustable between 30% and 100% of max. torque
Option	Proportional control (4 to 20 mA) Inverter (variable speed) PROFIBUS-DP communications

### Mechanical Specifications & Dimensions

Specification	Model	Semflex® VP Series				
		VP-010	VP-020	VP-060	VP-1	VP-2
Max. output torque (Nm)		125	250	600	1000	2000
Opening/closing speed (sec/90°)	High-speed type (50/60 Hz)	9/7.5	18/15	18/15	18/15	36/30
	Low-speed type (50/60 Hz)	18/15	36/30	36/30	36/30	72/60
Fitting flange size (ISO)		F07	F07	F10	F12	F14
Max. shaft dia. (mm)		28	28	42	60	60
Ambient temperature (°C)		-20 to 60				
Protection structure		IP68, Exd II BT4 explosion-proof (option)				
Weight (kg)		25	30	52		
Outer dimensions (mm)	φA	90	125	175		
	φB <sup>18</sup>	55	70	100		
	φC	70	102	140		
	D	8	8	8		
	E	M8	M10	M16		
	F	15	15	15		
	G	167	191	268		
	H	3	3	4		
	I	379	396	462		
	K	281	325	363		
	L	113	130	191		
	M	20	20	20		
	N	121	136	174		
	O	186	202	240		
	Q	64	60	111		
	R	68	65	141		
S	R70	R110	R110			
T	10	8	70			

Note : For improvement of performance, mechanical specifications and/or outer dimensions are subject to change without notice.

### Dimensions (mm)

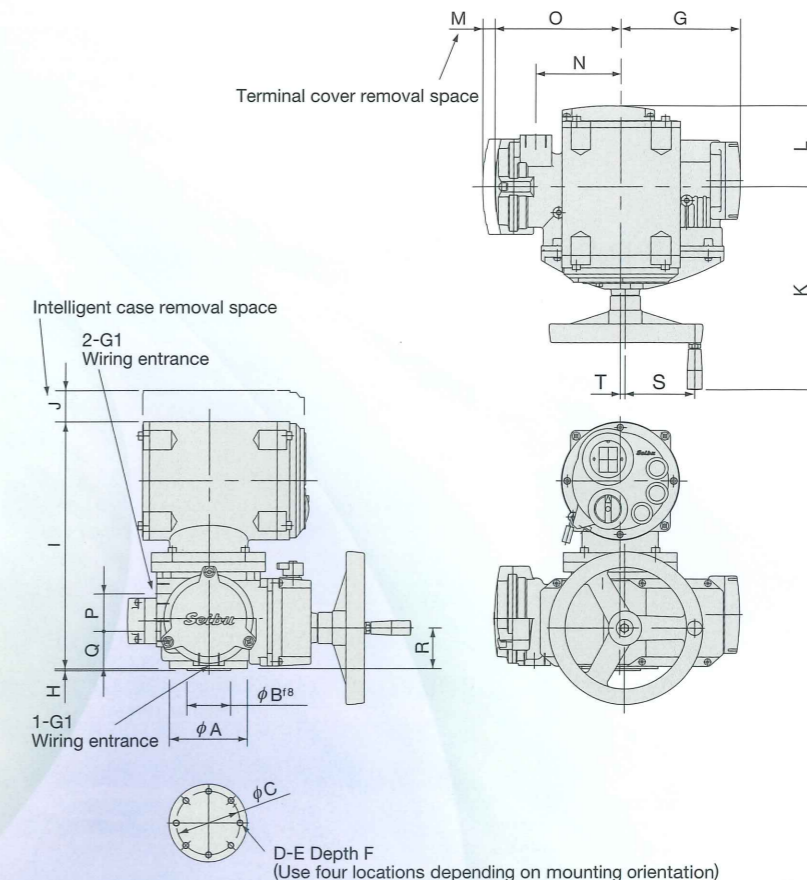

# Semflex<sup>®</sup>

## PROFIBUS-DP Control System Package Software

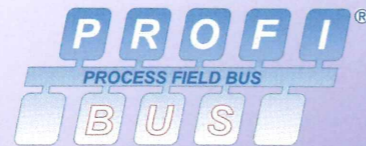

- ✓ Simple Operation
- ✓ Easier Maintenance
- ✓ Low Cost

Connect up to 30 power valve actuators. Connect up to 125 actuators to one master device (optional).



Monitor many types of data (torque, motor current, number of operations, etc.) through communications to enable self diagnosis and preventive maintenance to predict failures before they occur for actuator life, valve life, and other status management.

### Basic Communications Specifications PROFIBUS-DP

Communications protocol	PROFIBUS-DP	
Interface	RS-485	
Baud rate and transmission distance	Baudrate (kbit/s)	Cable length (without repeater)
	9.6	1200 m
	19.2	1200 m
	93.75	1200 m
	187.5	1000 m
	500.0	400 m
Wiring	Twist pair cable	
	Station types	DP Master class 1 DP Master class 2 DP slave
Number of connected stations	32 stations without repeater With repeater expandable up to 125	
Communications settings	Dete: 8 bit	
	Parity: Odd number	
	Stop bit: 1 bit	
Encoding method	Non Return to Zero	

### Semflex series Actuators PROFIBUS-DP Interface

Electronic controls	Integral controls Seibu Semflex series
Baud rate detection	Automatic
Control signals	OPEN
	STOP
	CLOSE
	Proportion control (Option)
	Limit switch OPEN/CLOSE
	Torque switch OPEN/CLOSE
	Opening/Closing signals
Feedback signals	Position REMOTE
	Valve position (Option)
	Self diagnosis data (Option)
Error signals	1. Motor protection tripped
	2. Torque abnormal
	3. Other abnormal

## Operation examples

Seibu Electric & Machinery Flow-Flexible

### Oil tanker equipment

#### 1. Compact and light

Smaller valve actuators simplify piping design for a more compact plant.

Example: Downsize piping, less framework to support actuators, less space for maintenance



#### 2. Easy maintenance

The simplified design with fewer parts requires less maintenance, reducing the number of working hours and employees.



### Plant equipment

#### 1. Profibus-DP communications system

By using a Profibus-DP system for automatic control of the Semflex A series of actuators, plant operations become more labor-saving with a higher degree of safety and higher quality.

One PC (the master) can operate and control 125 actuators.

An actuator control system using Profibus-DP communications is available upon request.

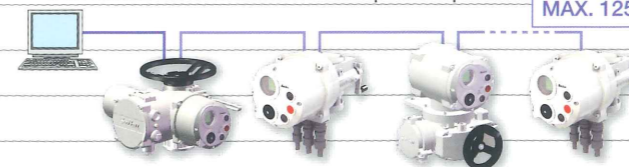

#### 2. Self-diagnostics

You can control the life and the condition of the actuator and the valve by high-speed monitoring of the torque, motor current, running hours, and other data. This system works for preventing troubles and helps in planned maintenance work.

